

MDBOX001

Video delle istruzioni:
Product Instructions:



<https://www.paffoni.it/info/modular-box?q=mdbox001>

INSTALLAZIONE SOLO ORIZZONTALE
HORIZONTAL INSTALLATION ONLY

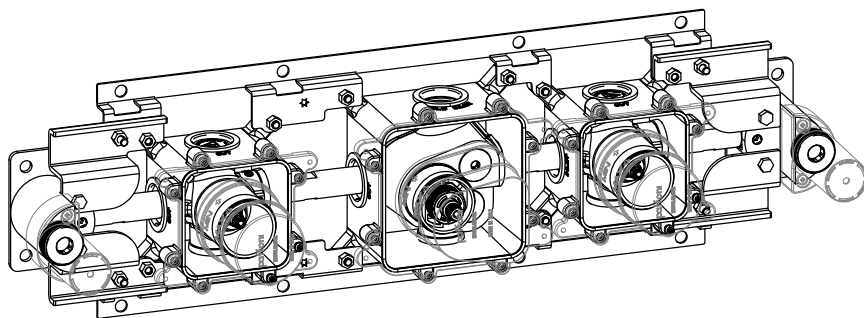

IST217
Rev.2020.00

INSTALLAZIONE VERTICALE VERTICAL INSTALLATION

1 Montaggio Assembly

Prima di chiudere il muro eseguire lo spurgo e la prova di pressione
Before concluding the wall finishing operation make purge and pressure test



EN1717

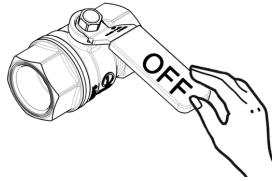

65±5°C



15±5°C



MIN - MAX



OK

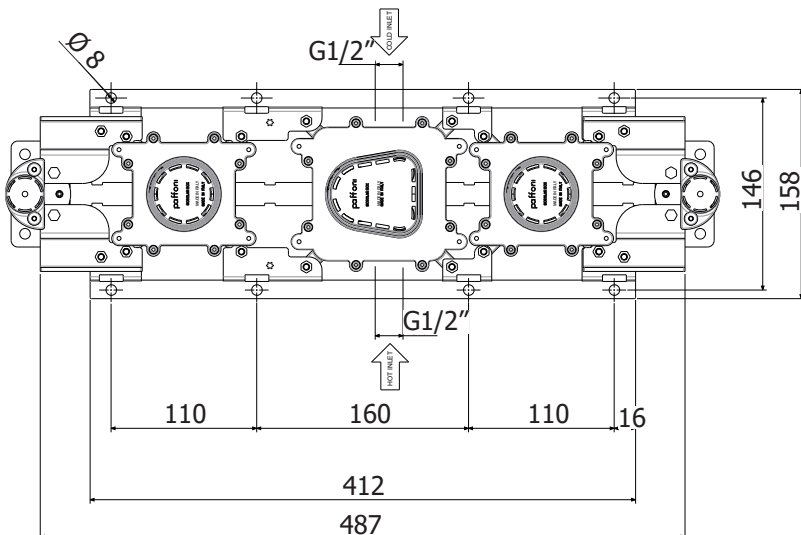
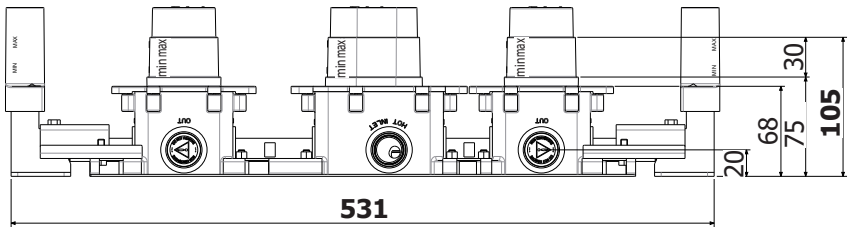

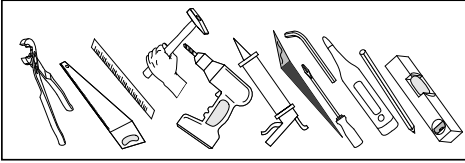

INSTALLAZIONE ORIZZONTALE CON
ORIENTAMENTO A SINISTRA
HORIZONTAL INSTALLATION WITH
DIRECTING ONLY IN LEFT SIDE

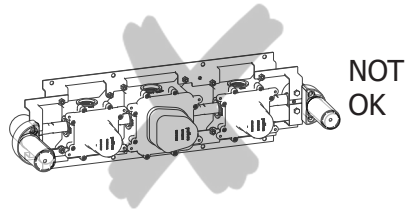
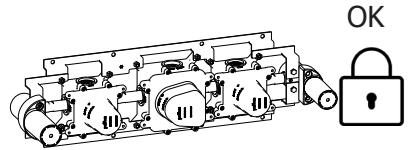
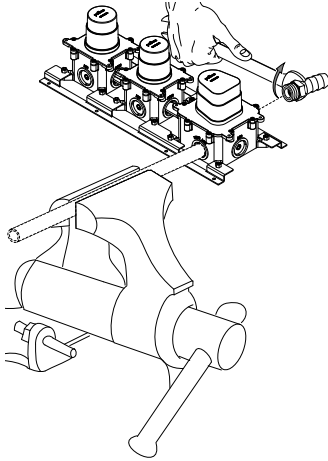

Non rimuovere i tappi
Don't remove plugs

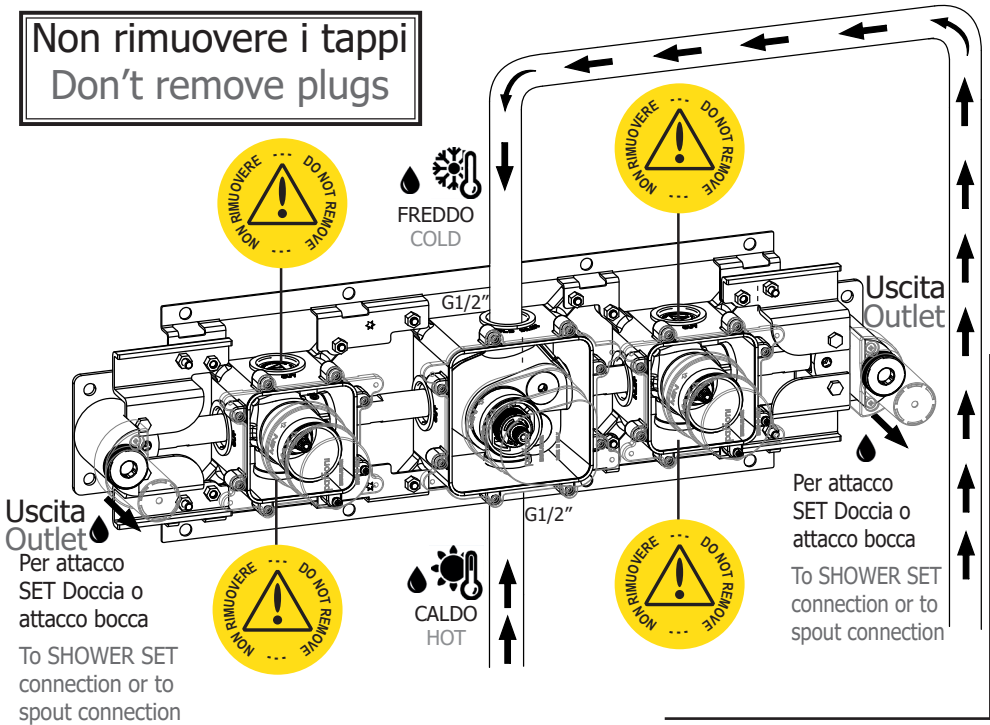

Ingombro dello spessore del rivestimento

Thickness size of the coating

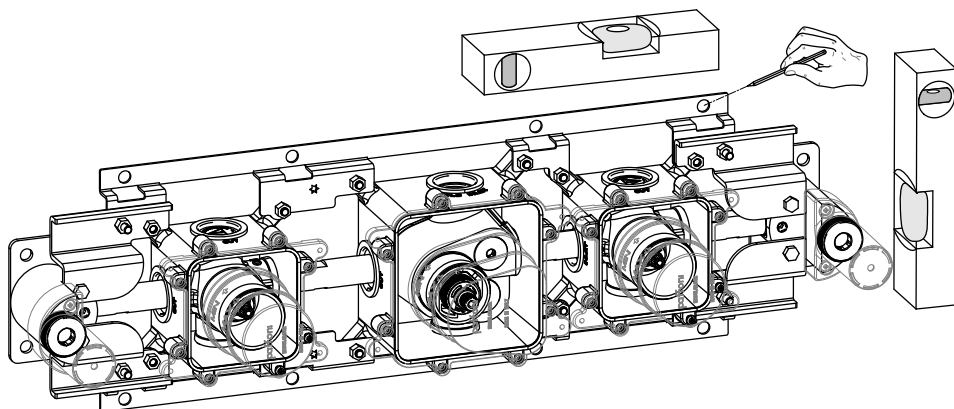
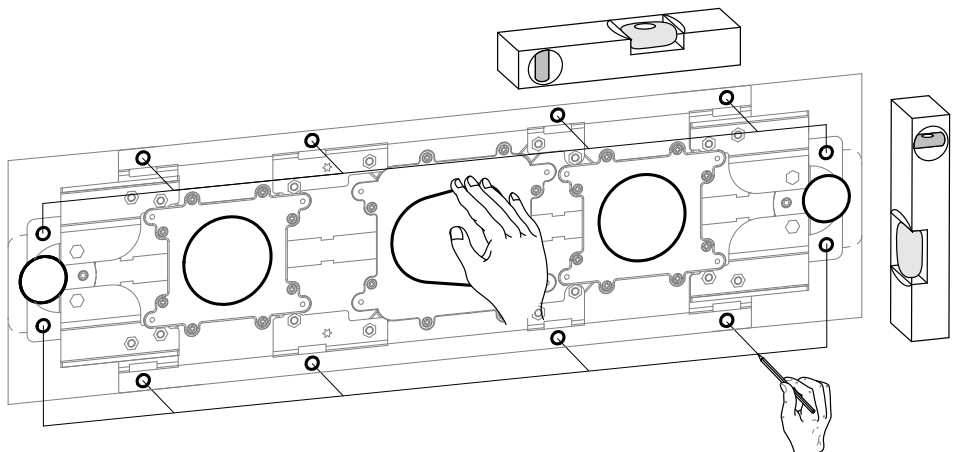
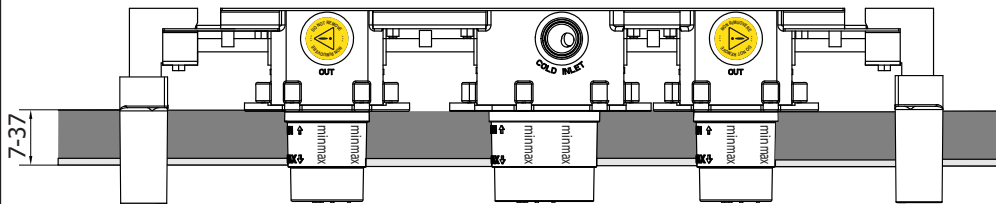

Tipologie di installazione Types of installations

1

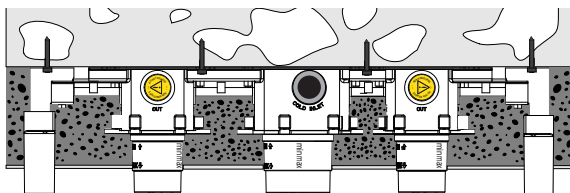

Fissaggio posteriore in appoggio sul muro

Back fixing resting on the wall

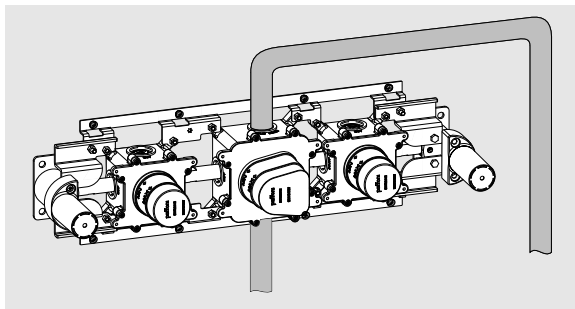

Prima di completare con i rivestimenti eseguire i **test pressione e spurgo.**

Before complete coating make **Purge and Pressure test.**
pp.7-8

2

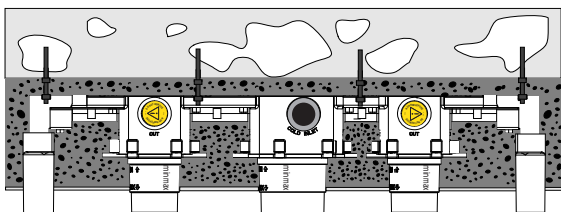

Fissaggio posteriore sospeso su tasselli

Back fixing hanging on dowels

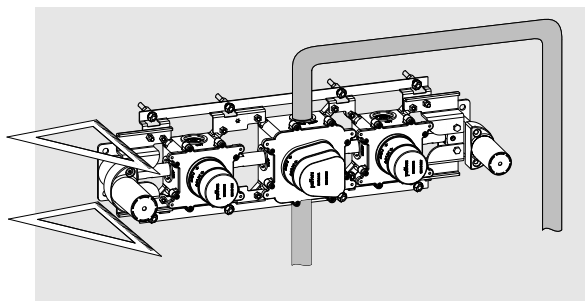

Prima di completare con i rivestimenti eseguire i **test pressione e spurgo.**

Before complete coating make **Purge and Pressure test.**
pp.7-9

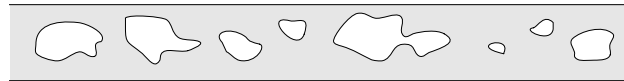

Fissaggio posteriore in interspazio

Back fixing in interspace

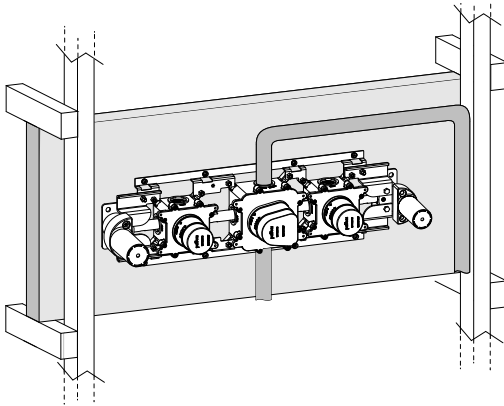
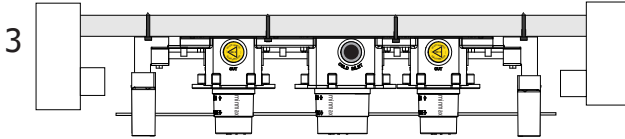

Prima di
completare con i
rivestimenti
eseguire i
**test pressione e
spurgo.**

Before complete
coating make
**Purge and
Pressure test.**
pp.7-8

Spurgo
Purge

a

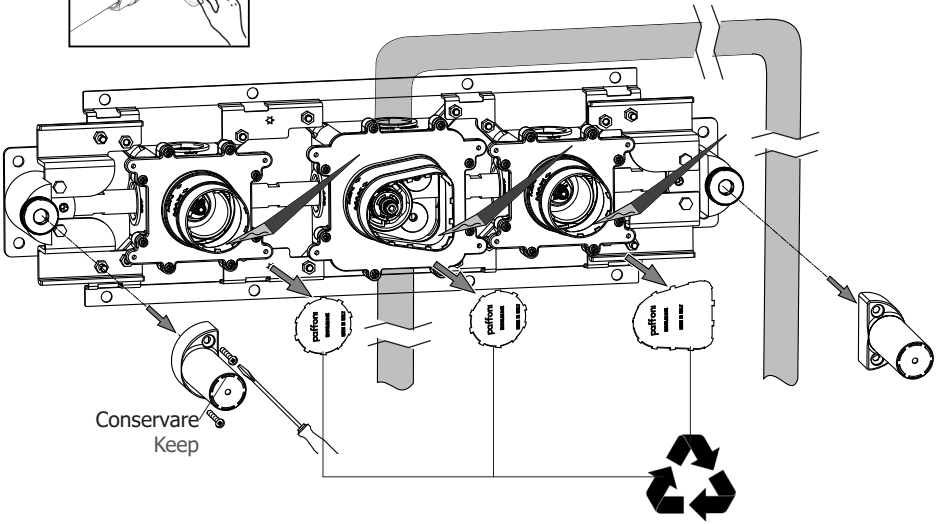
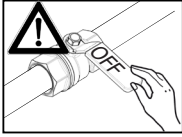

b

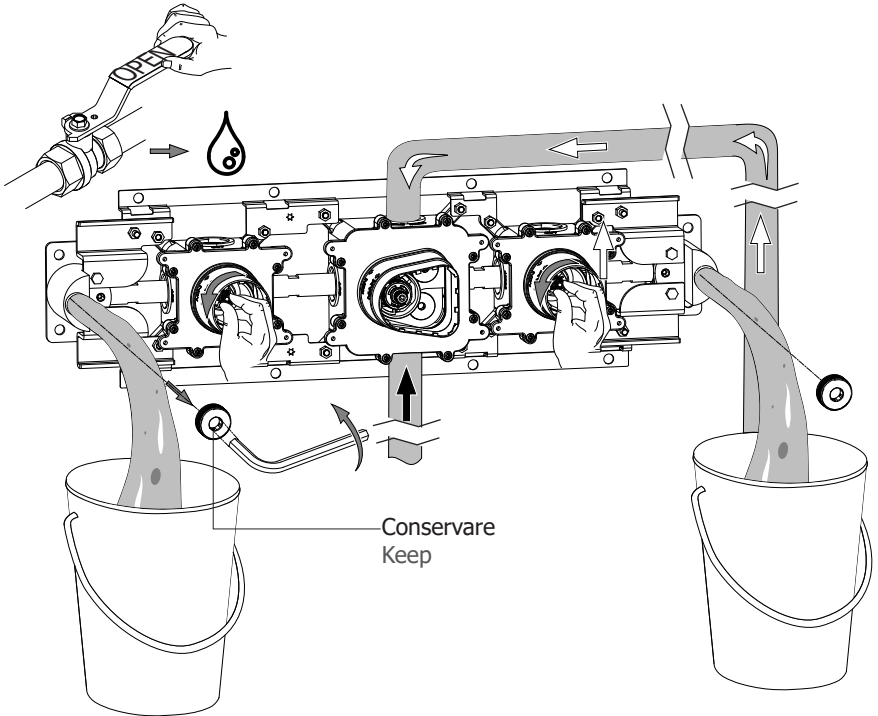

Test perdite e di pressione
Leak and pressure test

a

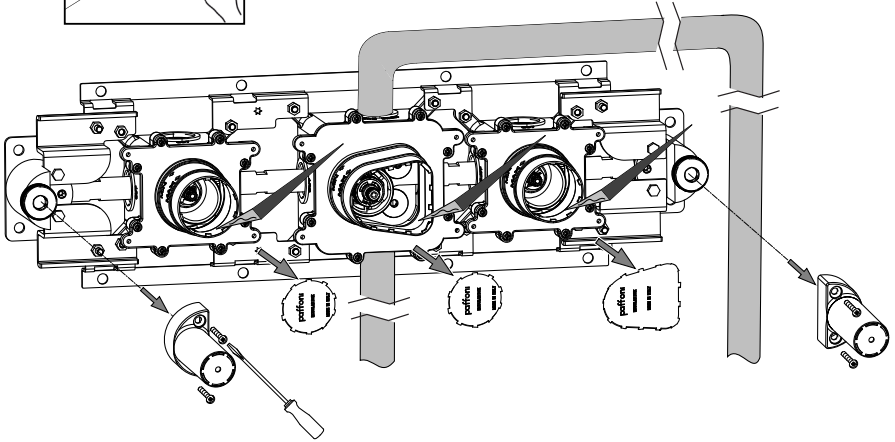
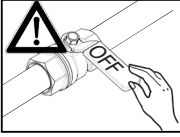

b

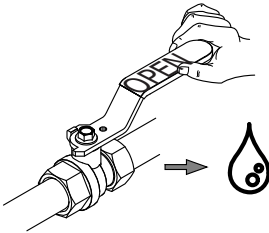

c

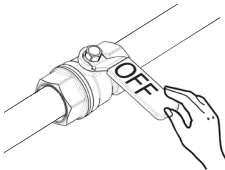

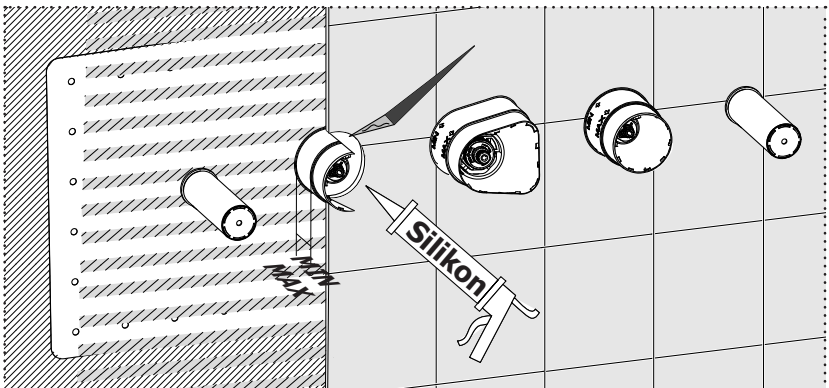
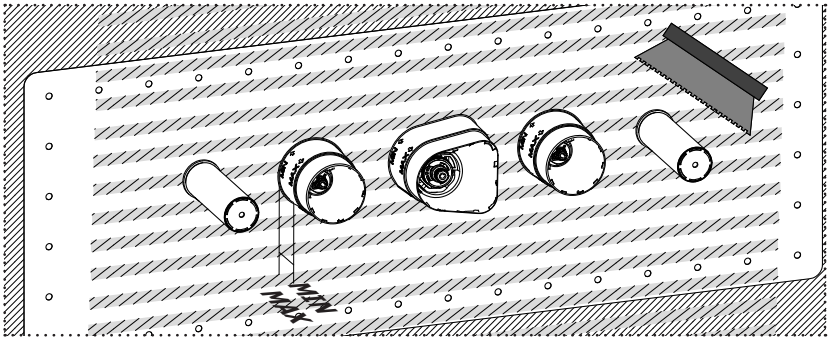
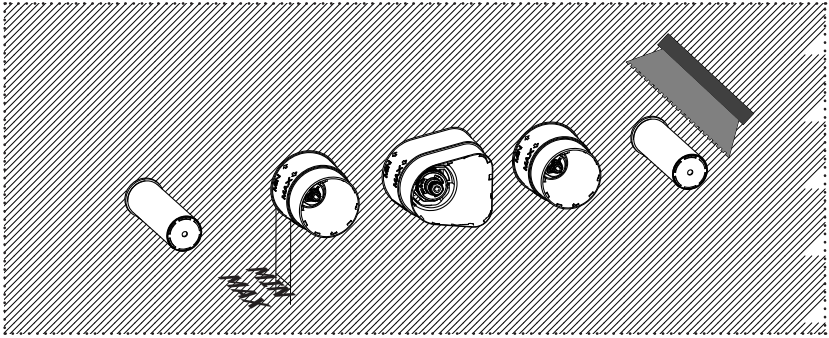
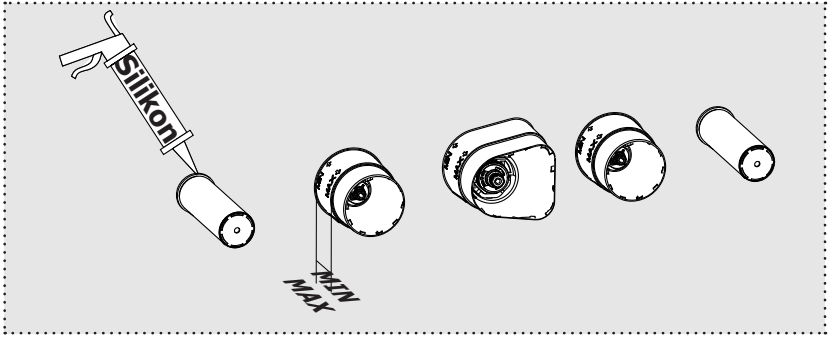

RAPPORTO PROVA DI PORTATA
FLOW RATE REPORT

MDBOX 001 + MDE 001

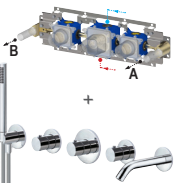
2 Funzioni Functions	Uscita Outlet	Pressione / Pressure (bar)										
		0,5	1,0	1,5	2,0	2,5	3,0	3,5	4,0	4,5	5,0	
	Portata Flow rate (l/min)	A	7,1	10,2	12,8	14,9	16,7	18,4	19,9	21,3	22,6	23,9
	B	4,9	7,5	9,4	11,0	12,3	13,6	14,7	15,7	16,7	17,7	
	A + B	9,1	13,4	17,0	19,7	22,2	24,4	26,5	28,4	30,2	31,8	

Sostituzione Vitoni ceramici
How to replace Ceramic Disk Valve

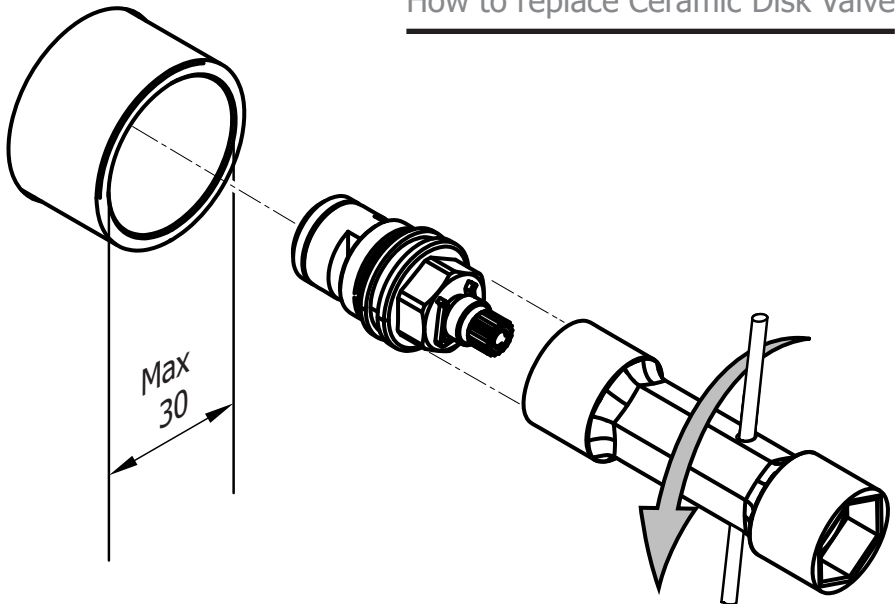

CH 17

Sostituzione Cartuccia Termostatica How to replace Thermostatic Cartridge

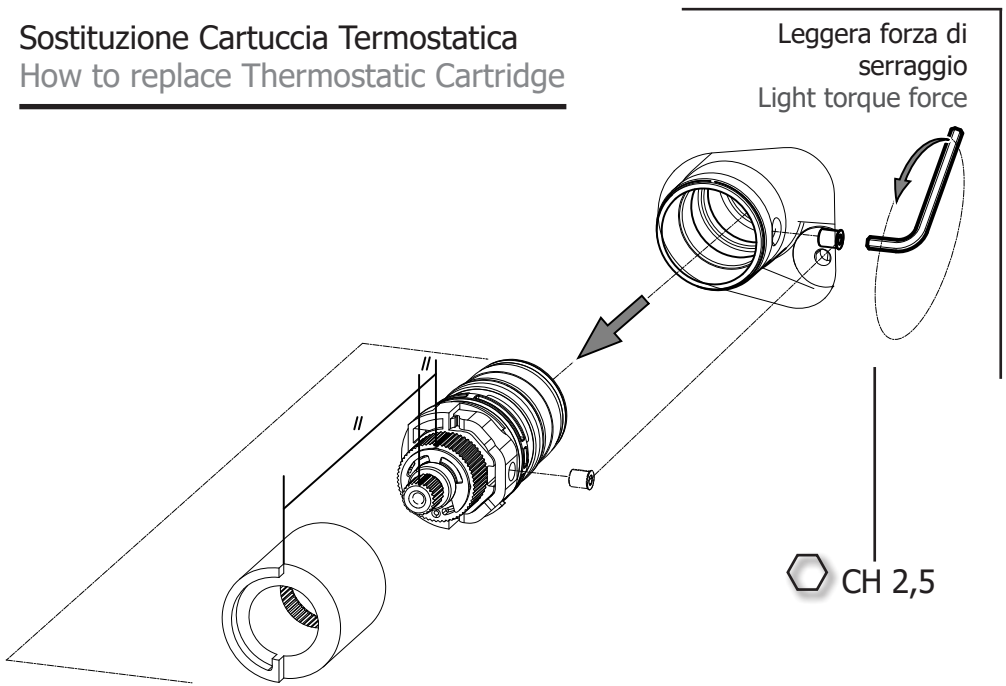

Sostituzione Sede con Valvolina antiritorno How to replace Seat with Check Valve

